



# Engineering Tasks Group (ENTAG)

## Capability Statements



## Who we are...

Engineering Tasks Group (ENTAG) is an Egyptian company established in 1995 and specialized in design and supply of systems and equipment for MSW treatment and disposal projects, it is one of the companies owned by a group specializing in providing environmental services, and includes a sister company which is “ECARU” specialized in the operation and maintenance projects for MSW and biomass management projects (collection, transportation, treatment).

ENTAG & ECARU group is working under the platform of Citadel Capital Company, the leading private equity firm in the Middle East and Africa. Citadel Capital’s 19 Opportunity-Specific Funds control Platform Companies with investments of more than US\$ 9.0 billion spanning 15 countries and 15 industries including energy, mining, agrifoods, cement, finance, transportation and retail.

Citadel Capital focuses on opportunities in the Middle East and Africa. In addition to its Cairo headquarters, the Firm has an office in Algiers and opened in 2010 an office in Nairobi, Kenya, as part of its expansion into East Africa with its acquisition of a controlling interest in Rift Valley Railways, the national rail operator of Kenya and Uganda.

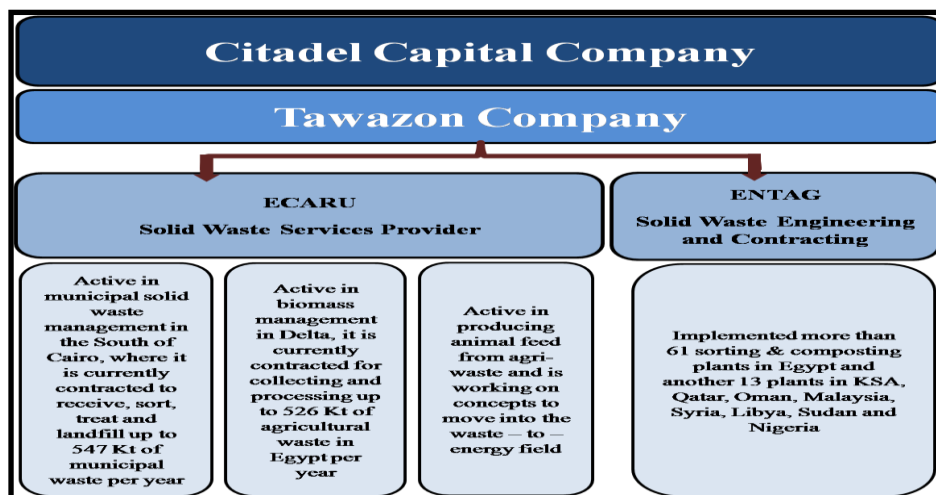

Chart no. (1): Group structure

ENTAG implement a quality system in conformity with the requirements of international standard ISO 9001 in quality and ISO 14001 in environment and ISO 18001 in occupational safety and health.



Chart no. (2): ISO certificates

ENTAG goal is to participate and remain at the highest level of progress in the management and waste treatment specializing and focus on everything related to this area and this is one of our largest advantages.

ENTAG Also established another two branches in Muscat- Sultanate of Oman and United Arab Emirates under the Name of “**ENTAG for Engineering and Environmental Tasks (LLC)**”.

### **Experience in Design and Construction of Sanitary Landfill and MSW**

ENTAG is specialized in the design and construction of solid waste treatment and disposal facilities. Since 2004 ENTAG has designed and constructed eight (8) major landfill facilities in Egypt, Oman, Nigeria, Syria and Emirates which has provided ENTAG with the privilege to hire and retain the most qualified landfill specialists in the Gulf, Middle East and Africa, Our team of landfill specialist having vast experience in landfill facility design, construction, operation, maintenance and monitoring in the USA, Germany, Gulf, Africa, and Asia. Our design and construction criteria and procedures usually follow the USEPA standards, and, in some occasions, German standards are applied based on client preference.

Landfill facilities which were designed and constructed by ENTAG consisted of landfill cells, leachate management and treatment systems, roads, administration buildings, Company Profile

workshops, weighbridges, landscape, site security, utilities, laboratories, and other features as may be required by the client such as composting plant, materials recovery facility, incinerators.

ENTAG also offer a range of integrated services as follows:

- MRF, recycling and composting facilities
  - Turn key projects
  - Supplying of machinery
  - Engineering services
- Biomass management projects
- MSW treatment and disposal projects



Chart no. (3): ENTAG line of business

**The following is a brief list of projects completed by ENTAG.**

**In 2018,** ENTAG Engineering and Environmental Tasks LLC: ENTAG Engineering and Environmental Tasks LLC: ENTAG is a UAE company, ENTAG Engineering and Environmental Tasks LLC has signed a contract with Sharjah City Municipality for Digging up a new garbage dump at the Landfill Site in AL Saga area for two cells (MSW and HSW) the duration of the project is 6 months.

Entag will provide the following services:

- Provision, Procurement and implementation (installation) of cell lining system, anchor trench lining materials, leachate collection system, leachate transfer system, shredded tire layers and gas venting system.
- Shear box tests for soil and lining materials.
- All related lining tests
- Project Management including Project planning and performance determination, Method statements, HSE plans, Risk assessment plans, QC/QA plans, Communication plans, Procurement plans, Financial management, Resource plans and allocation and Construction supervision.
- Landfill cell circular road including surface runoff trenches, All internal paths and Signage, Cells excavation & formation, Cells bottom grading, Cells bottom compaction, Cells slope formation, Embankment for anchorage trench, All Electrical work and Power Supply, Landscaping, Site clearing and site grading, Water and waste water network, Fire network, Site Verification (Surveying work and geotechnical investigation), All tests related to earth work, Supply and installation of Temporary facility and site accommodation and Mobilization of equipment, staff and portal cabinet and demobilization

**In 2017,** ENTAG Engineering and Environmental Tasks LLC: ENTAG is a UAE company.

ENTAG Engineering and Environmental Tasks LLC has signed a contract with Waste Management Authority - Government of Ras Al Khaimah for design and construction of Jazeerah Landfill Cell 3 with total cell 30,000 m<sup>2</sup>.

Entag will provide the following services:

- Liaison with stakeholders and subcontractors;
- Construction supervision
- Earth works supervision
- Liner Procurement, construction and Installation
- Leachate Collection Pipe & Leachate Collection and Removal System
- Leachate Suction Pump
- Project Hand over phase
- All Plans regarding procurement of lining and leachate collection and transfer system.
- Preparing the project Management schedule.



**In 2016**, ENTAG signed a contract with Titan cement plant Rehabilitation and Upgrading of MSW facilities of Beni Suf Governorate (El-Wasta – Somesta – Sanour).

Entag scope of work is Complete refurbishment for existing equipment and for electrical works and buildings include

Inspection, check, disassembly, supply new parts instead of the defective parts for work completion and the right operation, installation and reassembly of all supplies and accessories equipments and rehabilitation of the mobile equipments also supply new equipments for sanor facility as the following:

- Overbelt magnet
- Trommel Screen
- Organic collect conveyor
- Organic conveyor
- Bag opening
- weighbridge 60 tons

- ENTAG Engineering and Environmental Tasks LLC: ENTAG is a Omani company, Consists of three companies: Al Salsabel Trade and Cont. Est., Engineering Tasks Group ENTAG & Egyptian Company for Solid Waste Recycling ECARU ENTAG has signed a contract with Oman Environmental services holding company (Beah) for design and construction of An Expansion Of The Engineered Sanitary Landfill In BARKA with total cell 94,500 m2.

Entag will provide the following services:

- Excavation, grading and compaction of the landfill cell.
- Embankment and anchoring trench.
- Construction of the leachate and gas collection systems and evaporation pond.
- Construction of groundwater monitoring wells.
- Procurement of materials for the construction of the landfill cell, leachate and gas collection systems and evaporation ponds.
- Mobilization and demobilization of the specialized manpower and equipment for the construction of the landfill cell, leachate and gas collection systems and evaporation pond.

- ❑ ENTAG have made a joint venture agreement with AI HOOQANI UNITED LLC – Omani Company.  
ENTAG/ALHOOQANI JV has signed a contract with Oman Environmental services holding company (Bea'h) for design and construction of an Engineered landfill in Khasab with total area 60000 m<sup>2</sup>.

Entag will provide the following services:

- Excavation, grading and compaction of the landfill cell.
- Embankment and anchoring trench.
- Construction of the leachate and gas collection systems and evaporation pond.
- Construction of groundwater monitoring wells.
- Procurement of materials for the construction of the landfill cell, leachate and gas collection systems and evaporation ponds.
- Mobilization and demobilization of the specialized manpower and equipment for the construction of the landfill cell, leachate and gas collection systems and evaporation pond.

- ❑ ENTAG signed a contract with Titan cement plant for Supply RDF Equipment for Abees 1 – Alexandria.

ENTAG supply the following equipments to produce Alternative fuel:

- Trommel screen
- Wind sifter
- Distribution conveyor
- Light fraction material conveyor
- Heavy material conveyor
- Organic conveyor
- Wind sifter feeding conveyor

**In 2015**, ENTAG signed a contract with ENTAG signed a contract with PECS company to supply RDF equipments in Republic of Sudan.

ENTAG supply the following equipments to produce Alternative fuel:

- Trommel Screen 8m Feeding Conveyor
- Trommel Screen 8m.
- Organic Collect Conveyor
- Organic Conveyor
- Sorting Plant
- Reject Conveyor
- Reject Distribution Conveyor
- Primary Shredder Feed Conveyor
- Primary Shredder
- Primary Shredder Output Conveyor

- Fixed Trommel Screen 4 M
- Organic Conveyor 2
- Windshifter Feeding Conveyor
- Windshifter
- Heavy Material Conveyor
- Secondary Shredder Feed Conveyor
- Magentic Conveyor
- Magentic Conveyor Holder
- Secondary Shredder
- Shredded Material Conveyor 1
- Shredded Material Conveyor 2

**In 2014**, ENTAG signed a contract with Khartoum state- General Administration for the Development to develop the transfer station for Khartoum state- Republic of Sudan.

Entag is providing the following services:

- Electromechanical Supply.
- Electrical works for supplied items.
- Erection of supplied Electromechanical.
- Commissioning & start up and training for one week.

ENTAG signed a contract with Khartoum state- Republic of Sudan- General Administration for Design and Manufacturing of 560 Household Refuse Container.

ENTAG signed a contract with GIZ (the Deutsche Gesellschaft fur international zusammenarbeit) Gmbh (german Development cooperation) for Rehabilitation of the existing MRF with total capacity 15 ton / hr.- Khosooos - Khanka – Egypt.  
Entag scope of work is Inspection, check, disassembly, supply new parts instead of the defective parts for work completion and the right operation, installation and reassembly of all supplies and accessories.

ENTAG signed a contract with Abu Zaabal Engineering Industries Co– Egypt for supplying 6 Turning Machines.

ENTAG signed a contract with Maadi Company for Engineering Manufactures – Egypt for supplying 3 Rejects Continuous Balers with its feeding Conveyors.

ENTAG signed a contract with GIZ ( the Deutsche Gesellschaft fur international zusammenarbeit) Gmbh (german Development cooperation) for the Integrated Resource Recovery Center (IRRC) with total capacity 15 ton / hr- - Khosooos - Khanka – Egypt.

ENTAG is providing the following services:



Assembly and erection of the technological equipment; all necessary electrical, civil and ancillary works; testing, commissioning and handling over of technological equipment.

- ENTAG have made a joint venture agreement with Al Salsabeel Trading & Cont. Est (STCE) – Omani Company.

ENTAG/STCE JV has signed a contract with Oman Environmental services holding company (Bea'h) for design and construction of an Engineered landfill in Thumrayt with cell capacity 2,000,000 m<sup>3</sup>.

ENTAG is providing the following services:

- Excavation, grading and compaction of the landfill cell.
- Embankment and anchoring trench.
- Construction of the leachate and gas collection systems and evaporation pond.
- Construction of groundwater monitoring wells.
- Procurement of materials for the construction of the landfill cell, leachate and gas collection systems and evaporation ponds.
- Mobilization and demobilization of the specialized manpower and equipment for the construction of the landfill cell, leachate and gas collection systems and evaporation pond.

**In 2012**, ENTAG signed a contract with Konsadem associates LTD for Lagos State Government for the engineering, procurement and construction management of landfill, Material recovery facilities, composting facility, including all associated buildings, weighbridges, roads, landscape, site security, and utilities. The scope of work includes site selection, site investigations, survey, development of master plan, preparation of preliminary and final drawings and design documentations, as well as construction management and 6 month training on operation.

- ENTAG signed a contract with United Environmental, Inc.- Ras Shoqir -Red Sea governorate– Egypt. for Design and construction of municipal solid waste sorting, Recycling and Composting plant.

ENTAG is providing the following services:

Process design, site and topographical surveys; geotechnical investigations; detailed design and engineering for all civil, electrical works and mechanical equipment. Supply of equipment. Construction, Erection; Commissioning and Start – up services.

**In 2011**, ENTAG was awarded a contract to carry out the design, procurement, construction, operation and training of Tartos landfill facility-- Syria 126 t/d design capacity facility. The scope of work included the EPC for landfill cell accordance to USEPA standards, leachate management system, two weighbridges, administration building, laboratory, roads, surface runoff, landscape and fencing. The project was completed to the full satisfaction of the client: Military Construction Company.

Also ENTAG had signed another contract with Military Construction company for supplying & constructing a complete sorting unit as a turnkey project.

ENTAG is providing the following services: Process design, site and topographical surveys; geotechnical investigations; detailed design and engineering for all civil, electrical works and mechanical equipment. Supply of equipment. Construction, Erection; Commissioning and Start – up services.

❑ ENTAG signed a contract with Oman technical agency for supplying two mobile trommel screens which separate fines particles from over size one, The trommel screen production capacity is 2-3 ton/hr, and supplying two hammer mill which milling different types of dry agricultural waste such as maize stalks, the hammer mill production capacity is 1.5 ton/hr.

❑ ENTAG signed a contract with Muscat Municipality-Oman for supplying & erection equipment for transfer station .

ENTAG is providing the following services:

Process design; detailed design and engineering for mechanical equipment. Supply of equipment, erection and commissioning,

**In 2009**, ENTAG signed a contract with Seder Group Trading & Contracting Company- Jeddah – Kingdom of Saudi Arabia. for supplying & constructing a complete sorting unit as a turnkey project.

ENTAG is providing the following services: Process design, site and topographical surveys; geotechnical investigations; detailed design and engineering for all civil, electrical works and mechanical equipment. Supply of equipment. Construction, Erection; Commissioning and Start – up services.

❑ ENTAG signed a contract with Omdurman Company- Republic of Sudan for supplying & constructing a complete sorting unit as a turnkey project.

ENTAG is providing the following services: Process design, site and topographical surveys; geotechnical investigations; detailed design and engineering for all civil, electrical works and mechanical equipment. Supply of equipment. Construction, Erection; Commissioning and Start – up services.

- ❑ ENTAG signed a contract with agriculture Directorate in New Valley- El Kharga- Egypt for Provide the mechanical supply, machinery and laboratory equipment necessary to the construction and operation of palm waste recycling plant in The New Valley.

ENTAG is providing the following services: Process design detailed design and engineering for mechanical equipment. Supply of equipment, erection and commissioning.

**In 2008**, ENTAG signed a contract with Veolia Alexandria – Egypt for supplying mobile trommel screen for MSW to separate organic matter and reject from MSW

ENTAG is providing the following services: Supply of trommel screen, Erection, Commissioning and Start – up services.

- ❑ ENTAG signed a contract with waste collection and recycling co.Ltd (MEPCO) - Jeddah - Kingdom Of Saudi Arabia.for supplying & constructing a complete sorting unit as a turnkey project.

ENTAG is providing the following services: Process design, site and topographical surveys; geotechnical investigations; detailed design and engineering for all civil, electrical works and mechanical equipment. Supply of equipment. Construction, Erection; Commissioning and Start – up services.

**In 2007**, ENTAG was awarded the contract to design and build the sanitary landfill for the governorate of Bani\_Sweef, Egypt.

The scope of work included:

- Establishment of landfill for solid waste
- Design and operation of landfill
- Rehabilitation of the industry

ENTAG provided the following services: site investigation, survey, master plan, all design details, and documentation, construction of the landfill cell, evaporation pond and weighbridge, utilities, fence and gates and associated infrastructure. The work was completed on time and to the full satisfaction to the client: Abu-Kir Company for Engineering Industries.

Also Bani sueif Governorate, through its technical sector, signed an agreement with the Ministry of Military Production to serve the Governorate capital. ENTAG has signed a contracts with the ( Ministry of Military Production ) to Design Manufacture ,Supply,erection and construction of MSW sorting ,recycling and composting plant of El Wasta.

- ❑ ENTAG signed a contract with Saudi company for Enviromental works for supplying & erection equipment for transfer station at Ras Lafaan industrial city to serve the camp pearl GTL shell - Qater – El Doha.

ENTAG is providing the following services: Process design detailed design and engineering for mechanical equipment. Supply of equipment,erection and commissioning, The project is under construction.

The project main items are:

- size reduction, baling, crushing, weighting.

- ❑ ENTAG signed a contract with The Ministry of local development, through its technical sector, signed an agreement with the construction of 19 composting plants, to serve the Governorate capital, cities as well as marakez level cities (phase 5).

ENTAG provided the following services: Process design ,site and topographical surveys; geotechnical investigations; detailed design and engineering for all civil, architectural, electrical works and mechanical equipment. Supply of imported equipment. Construction management, supervision; testing, commissioning and start-up services.

- ❑ ENTAG signed a contract with Egyptian Enviromental Affair Agency (EEAA) providing equipments for biomass management (collection, transportation and treatment) for producing compost, animal feed,pellets, briquettes and altermative fuel to cement plants.

- ❑ **In 2006**, ENTAG signed a contract with General Company for business and services in Green Mountain Baidaa City - Libya for Technical support for operation, maintenance and quality control of compost resulted from municipal solid waste project in Baidaa City.

- ❑ **In 2005**, ENTAG signed a contract with the Ministry of Military Production for Design and construction units for producing compost from agriculture residue (rice straw) Kalabsho 1, 2 ( Dakahliya governorate)- Egypt.

- ❑ ENTAG signed a contract with Ms Smart Recycling (Malysia) for supplying & erection complete sorting & composting plant Saba Area as a turnkey project.

ENTAG is providing the following services: Process design, site and topographical surveys; detailed design and engineering for all civil, architectural, electrical works and mechanical equipment. Supply of equipment. Construction, erection; commissioning, the project is under construction.

- ❑ **In 2004**, ENTAG signed a contract with Onyx Alexandria – Egypt for supplying & constructing a complete sorting unit as a turnkey project. To serve as upgrading unit for the existing MSW sorting and composting plant.

- ❑ ENTAG was awarded the contract for Egypt's first municipal solid waste management facility "15th of May MSW Facility" in 2004. The contractual scope of work included the design, procurement, construction, operation, and maintenance for a period of 10 years (from 2004 to 2014) for sanitary landfill facility to accommodate 1,500- 2,000 ton/day of MSW, and to be designed and constructed in accordance to the united state environmental protection agency (USEPA) regulatory and technical requirements and international standards. The scopes of work included
  - Design and construction of landfill facilities in phases to accommodate the incoming waste for 10 years utilizing the areal foot print provided by the owner.
  - Design and build leachate management system and gas collection and venting system.
  - Design and build administration building to accommodate 25 staff, laborer building, and large workshop with fuel station, internal roads and roads leading to the facility for the main highways, laboratory, security wall around the site, landscape, utilities in addition to materials recovery facility and composting facility.
  
- ❑ **In 2003**, ENTAG signed a contract with Ministry of Military Production) to serve as an engineering contractor for Phases 2,3,4. with the construction of 32 composting plants, to serve the Governorate capital, cities as well as marakez level cities.
  
- ❑ **In 2001**, ENTAG signed a contract with Environmental Protection Agency Tripoli (Sawani area) for Design, supplying and construction of two sorting units for upgrading EL SAWANY MSW treatment plant.
  
- ❑ ENTAG signed a contract with Environmental Protection Agency (Tripoli Municipality) for supplying & constructing and operating Sedi – El Sayeh plant as a turnkey project to convert waste to organic compost with capacity 320 ton / day, which works efficiently in full since 2002 and until now.
  
- ❑ **In 2000**, ENTAG signed a contract with El Obour market Design and construction recycling and composting plant for El Obour Market.  
ENTAG provided the following services: Process design, site and topographical surveys; geotechnical investigations detailed design and engineering for all civil, architectural, electrical works and mechanical equipment. Supply of imported equipment. (Compost turning machine – star screen – skid loaders – hammer mill – bagging machine) Construction management, supervision; testing, commissioning and start-up services.
  
- ❑ **In 1999**, ENTAG signed a contract with the Ministry of Military Production for the construction of 15 May sorting, recycling and composting plant in south Cairo, to serve the Governorate capital, cities as well as marakez level cities.  
ENTAG provided the following services: Process design, site and topographical surveys; geotechnical investigations; detailed design and engineering for all civil,



architectural, electrical works and mechanical equipment. Supply of imported equipment. (turning machines, loaders and belt magnets)

- **In 1995**, ENTAG signed a contract for Common aerobic composting plant for treating of waste resulted from sewage treatment Plants for District of Zabaleen, Alexandria- Egypt.

Entag designed different treatment methods, units required to establish the project, the detailed design of all work required for the project. These efforts divided into 4 phases:

- Collecting the information about the site and the project and make full analysis of all the needs of the project
- Make the tender documents and agreements
- Implementation phase
- Operating factory

The factory is now operating

## □ Our Tools...

Our team of experts has firsthand knowledge of the successes and failures of existing technologies in the Egyptian environmental context. The key however, is that we realize that technology is a tool – not a universal remedy, and that finding suitable solutions to each case is crucial. Appropriate technological solutions must consider the entire scope of the problem – including economic and operational sustainability as well as environmental impacts – and often suggest resorting to practical solutions.



Picture no. (1): Design and technical office of ENTAG Company

## □ Our Approach...

As an experienced and dynamic company, we offer a proactive approach coupled with the energy to implement new prospects. We adapt our services to meet specific needs and use innovative technologies wherever appropriate. Flexibility and a positive perspective are essential elements to this approach.

According to our experience in the fields of design, manufacture, installation, operation and maintenance of municipal solid waste treatment facilities, and according to our solid knowledge of modern and conventional MSW treatment & disposal systems applied worldwide, we examine the project from the following four dimensions:

- **Environmental Dimension:**

Increasing the amount of recovery to the maximum level by sorting recyclables out of the wastes mainstream, and composting most of organics and baling of rejects to be sold as alternative fuel thus, reducing the amount of land-filled wastes, and consequently reducing air, soil, and groundwater pollution. Avoiding conventional incineration units prevents air pollution as well.

- **Economic dimension:**

Recyclables, unsuitable for fermentation or compost production, are in fact highly valuable materials as they can be recycled and reused. Secondary manufacturing industries can be established alongside the composting plant in which recyclables can be reprocessed and marketed whether locally or internationally, generating economic revenues and providing additional job opportunities.

- **Sustainability dimension:**

Simplifying the operational process as well as the equipment utilized in order to ensure a reduction in capital costs and operation & maintenance costs.

- **Social dimension:**

Using a labor based system instead of a fully automated system is more suitable for the Middle East social aspect, because it fights unemployment and avoids high costs.

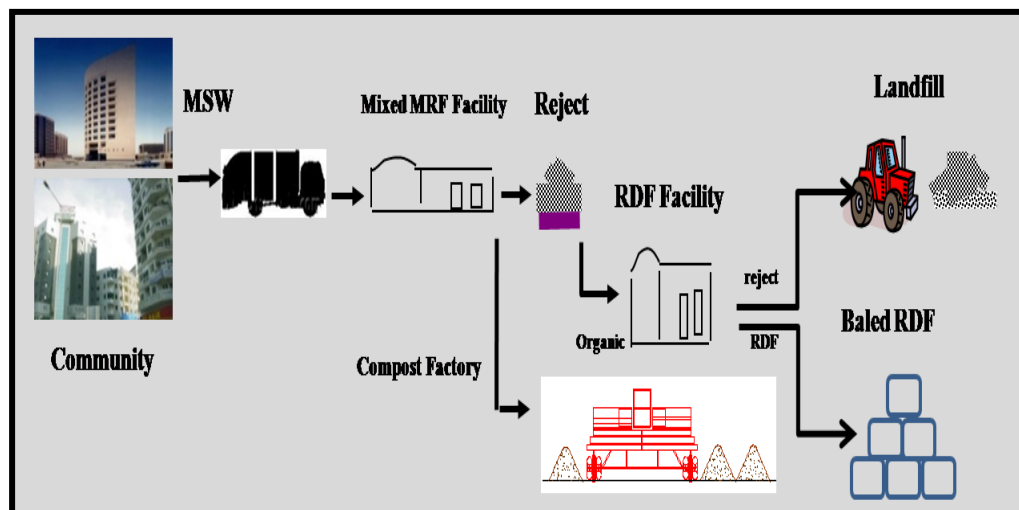

Chart no. (4): ENTAG's strategy for waste management

## □ Scope of Services

### ENTAG provides the following activities:-

- Design solid waste recycling system.
- Market research and technical studies and presentations.
- Design and specify facility components and equipment.
- Engineering drawings of mechanical equipment and construction drawings of civil and electrical works.
- Construction supervision.
- Provide technical support during operation, training, and after sales services.



Picture no. (2): Supplying & installing equipment for a transfer station-Oman

## □ Main Considerations:

- Upgrade with most advanced technology.
- Survey technologies and equipment worldwide.
- Consider Middle Eastern conditions regarding climate, levels of technology, human resources, etc.
- Simplify and avoid overly complicated systems.
- Cooperation with international companies on recycling equipment & systems.
- Recycling waste to produce useful products to the region (for example compost and alternative fuel).

**Foreign Partners:**

Ser.	Equipment Name	Equipment	Logo	Origin
1	Wood Chopper			U.S.A
2	Turning Machine (Scarap)			U.S.A
3	Bagging Machine			U.S.A
4	Glass Separator			U.S.A
5	Loader			U.S.A
6	Excavator			U.S.A
7	Metal Conveyor			Turkey
8	Magnetic Belt			Netherlands
9	Continuous Baler			Turkey
10	Continuous Baler			Italy
11	Fork Lift			England
12	Refused Compactor			Germany
13	Truck			Japan
14	Tractor			Holland
15	Press Container			U.S.A
16	Intermediate Sorting Station			Turkey
17	Hay Grinder			U.S.A
18	Wood Grinder			U.S.A
19	Compactor			Germany
20	Geared Motor			Germany
21	Round Baler			Norway

Table no. (1): ENTAG's Foreign Partners

The above-mentioned companies have been selected carefully so that their experiences would cover all the project components.



**Local Partners:**

ENTAG cooperates with the largest manufacturing companies in Egypt to manufacture local supplies according to design and shop drawing from ENTAG and under its supervision. These factories are:













Ser.	Company	Equipment Name	Equipment	Logo
1	Abu Qir for Engineering Industries (F-10)	Conveyorbelts		
2	El Maadi for Engineering Industries (F-54)	Bag breaker-slicer		
3	Abu Zaabal for Engineering Industries (F-100)	Rotary screens and composting machines		
4	Egyptian Tanks Plants (F-200)	Skid steer loaders		
5	Helwan Machinery Equipment	Grinding agricultural residues machines and recyclables balers		
6	Unitel	Conveyors		

Table no. (2): ENTAG's Local Partners

ENTAG has acquiring experience in operation, maintenance, and marketing through the Egyptian Company for solid waste recycling (ECARU), its sister company. ECARU runs nine recycling plants – designed by ENTAG and others – with technical support, maintenance, and development from ENTAG; these projects are:

1. **Dakahlia governorate:** Municipal solid waste treatment and disposal project
2. **15<sup>th</sup> May:** Landfilling and processing services for southern zone in Cairo.
3. **Minia Facility:** Composting of agricultural residues.
4. **Obour Facility:** Whole market waste recycling.
5. **El Nobaria:** Composting of agriculture and animal waste.
6. **El Arabia:** Organic composting plant.
7. **Kattamia Facility:** MSW treatment, composting, recyclable separation.
8. **EL-Swany Facility:** MSW treatment, composting, recyclable separation - Libya, Tripoli.
9. **Kalabsho:** Collection and transportation and treatment of agriculture waste.
10. **Sharqia, Kalubia, Gharbia and Dakahlia governorates:** Collection and transportation and treatment of agriculture waste.
11. **Wady El Mulak and El Nobaria:** Collection and grinding of trim citrus and fruits trees residues.

ECARU signed a contract with CEMEX Company to supply 300,000 tons of biomass in addition to 50,000 tons of RDF feed stock from MSW.



Picture no. (3): Alternative fuel to cement plants

## □ Our Specific Experience in SWM

This experience is a result of interaction and recognizing of the company to the extent of the problem of solid waste, so many factories were established for processing it in different regions from all over the Arab Republic of Egypt and abroad

### ➤ In Egypt

- Design and supervision of 32 municipal solid waste separation and composting facilities with capacity of 160 ton/day.
- Design and supervision of 2 municipal solid waste separation and composting facilities with capacity of 320 ton/day.
- Design of a municipal solid waste separation and composting facility with capacity of 640 ton/day.
- Design of a municipal solid waste separation and composting facility with capacity of 960 ton/day.
- Turnkey projects design and construction of agricultural residues composting facility with capacity of 200 ton/day.
- Design and supervision of whole market waste composting facility with capacity 200 ton/day.
- Integrated Resource Recovery Center (IRRC) with total capacity 15 ton / hr with GIZ.
- Supply 6 Turning Machines for Abu Zaabal Engineering Industries Co.(AZE) (Factory 100).
- Supply 3 Rejects Continuous Balers with its feeding Conveyors Maadi company for Engineering Manufactures- (factory 54).



Picture no. (4): Landfilling and processing services for southern Zone in Cairo- Egypt



Picture no. (5): GIZ project

➤ **In Nigeria**

- Engineering, procurement and construction management of landfill with capacity 360 ton / day.
- Design and build municipal solid waste recycling and treatment plant with capacity 900 ton / day.



Picture no. (6): integrated waste management project- Nigeria

➤ **In Libya**

- Designing plant for converting waste into compost and retrieval recyclables capacity 320 ton / day (Turnkey project).
- Upgrading plant for converting waste into compost and retrieval recyclables capacity 500 ton /day.
- Training, operation and maintenance of solid waste treatment units.

➤ **In Malaysia**

- Design, supply and installation of plant to convert waste into compost and retrieval recyclables capacity 500 ton / day.



Picture no. (7): Sorting and recycling plant - Malaysia

➤ **In Qatar**

- Supplying equipments for transfer station capacity 50 ton / day.



Picture no. (8): Transfer station- Qatar



➤ **In Saudi Arabia**

- Designing and construction of municipal solid waste sorting and recycling plant with capacity 4200 ton / day.
- Design, supplying and construction of commercial and industrial waste sorting and recycling plant with 480 ton / day



Picture no. (9): Seder sorting and recycling plant - Saudi Arabia

➤ **In Sudan**

- Designing and construction of municipal solid waste sorting and recycling plant in Om Durman with capacity 960 ton / day.
- Development of three transfer station for Khartoum state capacity 800 ton/day
- Design and Manufacturing of 560 Household Refuse Container:



Picture no. (10): Om durman sorting and recycling plant - Sudan

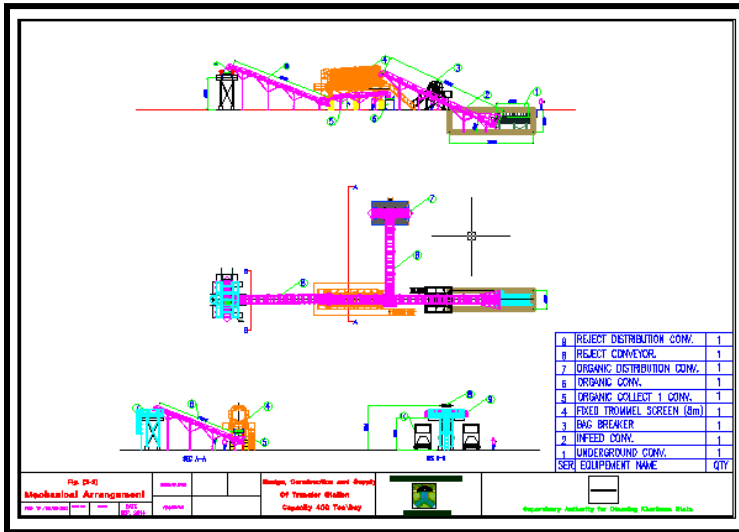

Picture no. (11): transfer station for Khartoum state - Sudan

Picture no. (12): Household Refuse Container

### ➤ In Oman

- Supplying composting equipments for Sultan Qaboos farm.
- Supplying & installing equipments for a transfer station.
- Design And Construction of An Engineered Sanitary Landfill In Khasab with total area 60000 m<sup>2</sup>.
- Design and Construction of an Engineered landfill in Thumrayt with cell capacity 2,000,000 m<sup>3</sup>.



Picture no. (13): Transfer station - Oman

➤ **In Syria**

- Designing and construction of municipal solid waste sorting and recycling plant with capacity 315 ton / day.
- The design, procurement, construction, operation and training of Tartos landfill facility with capacity 126 ton / day.



Picture no. (14): Municipal solid waste sorting and recycling plant - Syria

❖ **The company made a lot of research to provide technology that can be applied industrially in the following fields:**

1. Recycling of waste from the sugar industry.
2. Techniques and methods used in the recycling of waste from food industries.
3. Recycling of waste from oil industry, glucose and dry drinks.
4. Production of pectin from waste plant.
5. Modern technologies for the production of Mushrooms.
6. Recycling of waste resulting from date.
7. Steps of processing common composting.
8. Reject disposal methods to product fuel.

❖ **Technical studies prepared by ENTAG:**

- a. Using of sugar industries residues (filter mud) for producing compost, alternative fuel and animal feed.
- b. Using of alternative fuels in cement kilns.
- c. Technical, financial and contracting needs for integrated management of MSW treatment and disposal projects in Egypt.
- d. Egyptian experience of CDM projects.
- e. Windrow covering system.
- f. Biomass management projects in Egypt :
- g. (Collection, transportation, grinding, baling, animal feed production, compost production, agro pellets production and alternative fuel to cement plants)
- h. Date waste processing.
- i. Food industry waste processing.

As a result of accumulated experience in the field of environmental, ENTAG is currently providing environmental consulting in the following fields:

1. Integrated management of municipal solid waste.
2. Environmental planning.
3. Feasibility studies.
4. Training.



## PROJECT DESCRIPTION SHEET

<b>Project Name</b>	<b>Digging up a new garbage dump at the Landfill Site in AL Saga area</b>
<b>Project Location</b>	The Sharjah City - United Arab Emirates
<b>Project Duration</b>	Jan. 2018 – July 2018
<b>Required Expertise</b>	Engineering Capabilities in Design and Construction of sanitary landfill.
<b>Project Description</b>	<p>ENTAG Engineering and Environmental Tasks LLC: ENTAG is a UAE company, ENTAG Engineering and Environmental Tasks LLC has signed a contract with Sharjah City Municipality for Digging up a new garbage dump at the Landfill Site in AL Saga area for two cells (MSW and HSW) the duration of the project is 6 months.</p> <p>Entag will provide the following services:</p> <ul style="list-style-type: none"> <li>• Provision, Procurement and implementation (installation) of cell lining system, anchor trench lining materials, leachate collection system, leachate transfer system, shredded tire layers and gas venting system.</li> <li>• Shear box tests for soil and lining materials.</li> <li>• All related lining tests</li> <li>• Project Management including Project planning and performance determination, Method statements, HSE plans, Risk assessment plans, QC/QA plans, Communication plans, Procurement plans, Financial management, Resource plans and allocation and Construction supervision.</li> <li>• Landfill cell circular road including surface runoff trenches, All internal paths and Signage, Cells excavation &amp; formation, Cells bottom grading, Cells bottom compaction, Cells slope formation, Embankment for anchorage trench, All Electrical work and Power Supply, Landscaping, Site clearing and site grading, Water and waste water network, Fire network, Site Verification (Surveying work and geotechnical investigation), All tests related to earth work, Supply and installation of Temporary facility and site accommodation and Mobilization of equipment, staff and portal cabinet and demobilization.</li> </ul>

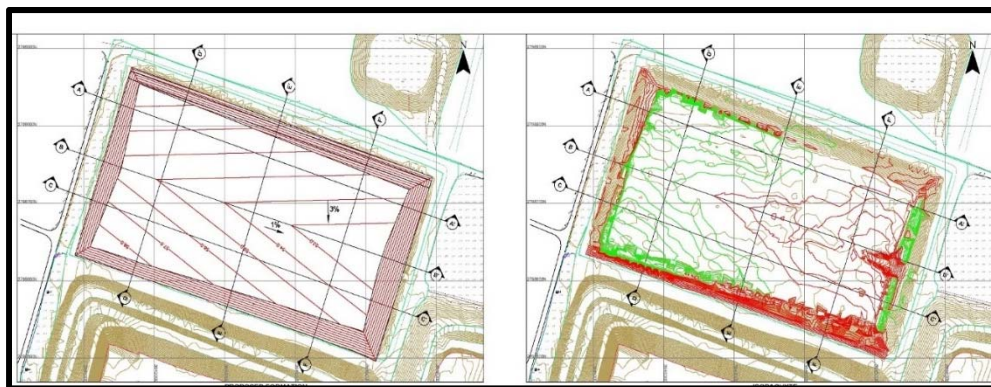

Picture no. (1): Sharjah General Layout

## PROJECT DESCRIPTION SHEET

<b>Project Name</b>	<b>Design and Construction of Jazeerah Landfill Cell 3</b>
<b>Project Location</b>	Ras Al Khaimah –United Arab Emirates
<b>Project Duration</b>	Nov. 2017 – Aug. 2018
<b>Project Capacity</b>	Total Cell Area 30,000 m <sup>2</sup> .
<b>Required Expertise</b>	Engineering Capabilities in Design and Construction of sanitary landfill.
<b>Project Description</b>	<p>ENTAG Engineering and Environmental Tasks LLC: ENTAG is a UAE company, ENTAG Engineering and Environmental Tasks LLC has signed a contract with Waste Management Authority - Government of Ras Al Khaimah for design and construction of Jazeerah Landfill Cell 3 with total cell 30,000 m<sup>2</sup>.</p> <p>Entag will provide the following services:</p> <ul style="list-style-type: none"> <li>• Liaison with stakeholders and subcontractors;</li> <li>• Construction supervision</li> <li>• Earth works supervision</li> <li>• Liner Procurement, construction and Installation</li> <li>• Leachate Collection Pipe &amp; Leachate Collection and Removal System</li> <li>• Leachate Suction Pump</li> <li>• Project Hand over phase</li> <li>• All Plans regarding procurement of lining and leachate collection and transfer system.</li> <li>• Preparing the project Management schedule.</li> </ul>

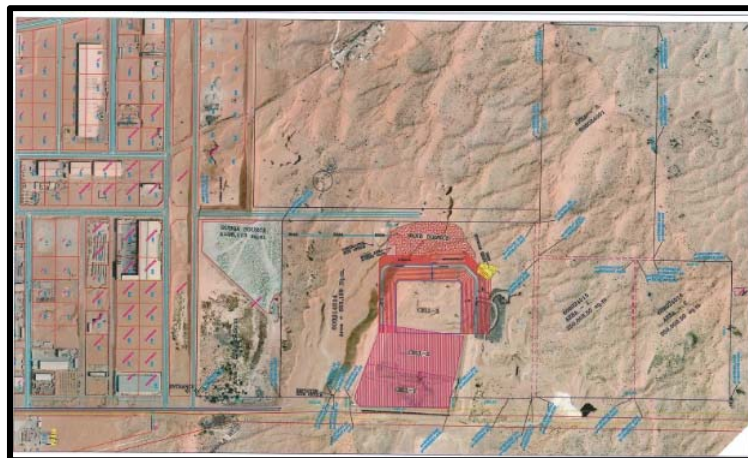

Picture no. (2): Jazeerah General Layout



## PROJECT DESCRIPTION SHEET

<b>Project Name</b>	<b>Design And Construction of An Expansion Of The Engineered Sanitary Landfill In BARKA</b>
<b>Project location</b>	South Al-Batinah Governorate - Barka - Sultanate Of Oman
<b>Project Duration</b>	Nov. 2016 – Oct. 2017
<b>Project Capacity</b>	Total Cell Area 94,500 m <sup>2</sup> .
<b>Required Expertise</b>	Engineering Capabilities in Design and Construction of sanitary landfill.
<b>Project Description</b>	<p>ENTAG Engineering and Environmental Tasks LLC: ENTAG is a Omani company, Consists of three companies: Al Salsabel Trade and Cont. Est., Engineering Tasks Group ENTAG &amp; Egyptian Company for Solid Waste Recycling ECARU</p> <p>ENTAG has signed a contract with Oman Environmental services holding company (Bea'h) for design and construction of An Expansion Of The Engineered Sanitary Landfill In BARKA with total cell 94,500 m2.</p> <p>Entag will provide the following services:</p> <ul style="list-style-type: none"> <li>• Excavation, grading and compaction of the landfill cell.</li> <li>• Embankment and anchoring trench.</li> <li>• Construction of the leachate and gas collection systems and evaporation pond.</li> <li>• Construction of groundwater monitoring wells.</li> <li>• Procurement of materials for the construction of the landfill cell, leachate and gas collection systems and evaporation ponds.</li> <li>• Mobilization and demobilization of the specialized manpower and equipment for the construction of the landfill cell, leachate and gas collection systems and evaporation pond.</li> </ul>



Picture no. (3): Barka General Layout

## PROJECT DESCRIPTION SHEET

<b>Project Name</b>	<b>Design And Construction of An Engineered Sanitary Landfill In Khasab</b>
<b>Project location</b>	Musandam Governorate- Khasab - Sultanate Of Oman
<b>Project Duration</b>	Nov. 2016 – Mar. 2017
<b>Project Capacity</b>	Total Cell Area 60,000 m <sup>2</sup> .
<b>Required Expertise</b>	Engineering Capabilities in Design and Construction of sanitary landfill.
<b>Project Description</b>	<p>ENTAG have made a joint venture agreement with AI HOOQANI UNITED LLC – Omani Company.</p> <p>ENTAG/ALHOOQANI JV has signed a contract with Oman Environmental services holding company (Bea'h) for design and construction of an Engineered landfill in Khasab with total area 60,000 m<sup>2</sup>.</p> <p>Entag will provide the following services:</p> <ul style="list-style-type: none"> <li>• Excavation, grading and compaction of the landfill cell.</li> <li>• Embankment and anchoring trench.</li> <li>• Construction of the leachate and gas collection systems and evaporation pond.</li> <li>• Construction of groundwater monitoring wells.</li> <li>• Procurement of materials for the construction of the landfill cell, leachate and gas collection systems and evaporation ponds.</li> <li>• Mobilization and demobilization of the specialized manpower and equipment for the construction of the landfill cell, leachate and gas collection systems and evaporation pond.</li> </ul>

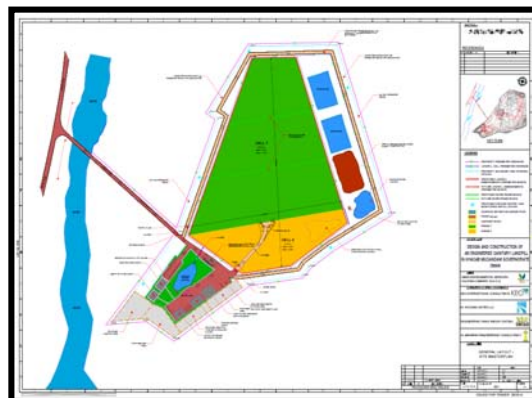

Picture no. (4): khasab General Layout

## PROJECT DESCRIPTION SHEET

<b>Project Name</b>	<b>Rehabilitation and Upgrading of MSW facilities of Beni Suf Governorate (El-Wasta – Somesta – Sanour)</b>
<b>Project location</b>	Beni Suf Governorate (El-Wasta – Somesta – Sanour) - Egypt
<b>Project Capacity</b>	45 Ton/hr
<b>Required Expertise</b>	Engineering capabilities in Rehabilitation and Upgrading of MSW facilities
<b>Project Duration</b>	Nov. 2016 –Apr. 2017
<b>Project Description</b>	<p>ENTAG had signed a contract with Titan Cement Plant For Rehabilitation and Upgrading of MSW facilities of Beni Suf Governorate of 3 existing facilities (El-Wasta – Somesta – Sanour).</p> <p>Entag scope of work is Inspection, check, disassembly, supply new parts instead of the defective parts for work completion and the right operation, installation and reassembly of all supplies and accessories and Refurbishment of mechanical equipment and mobile equipment and Refurbishment of electrical works and Refurbishment of civil buildings.</p> <p>Also supply new equipment:</p> <ul style="list-style-type: none"><li>▪ Over belt magnet</li><li>▪ Trommel Screen</li><li>▪ Organic collect conveyor</li><li>▪ Organic conveyor</li><li>▪ Bag opening</li><li>▪ weighbridge 60 tons</li></ul>



Picture no. (5): Rehabilitation of Sanour Facility

## PROJECT DESCRIPTION SHEET

<b>Project Name</b>	<b>Supply RDF equipments</b>
<b>Project location</b>	Abees 1 – Alexandria. - Egypt
<b>Project Capacity</b>	10-12 ton / hr
<b>Required Expertise</b>	Engineering Capabilities in Design
<b>Project Duration</b>	Aug. 2016 –April. 2017
<b>Project Description</b>	<p>ENTAG signed a contract with Titan cement plant for Supply RDF Equipment for Abees 1 – Alexandria.</p> <p>ENTAG supply the following equipments to produce Alternative fuel:</p> <ul style="list-style-type: none"><li>▪ Trommel screen</li><li>▪ Wind sifter</li><li>▪ Distribution conveyor</li><li>▪ Light fraction material conveyor</li><li>▪ Heavy material conveyor</li><li>▪ Organic conveyor</li><li>▪ Wind sifter feeding conveyor</li><li>▪ Bag opener</li></ul>



Picture no. (6): RDF Equipment

## PROJECT DESCRIPTION SHEET

<b>Project Name</b>	<b>Supply RDF Equipments</b>
<b>Project location</b>	Republic of Sudan
<b>Project Capacity</b>	15 Ton/hour
<b>Required Expertise</b>	Engineering Capabilities in Design
<b>Project Duration</b>	Dec.2015 – ongoing
<b>Project Description</b>	<p>ENTAG signed a contract with PECS company to supply RDF equipments.</p> <p>ENTAG supply the following equipments to produce Alternative fuel:</p> <ul style="list-style-type: none"> <li>• Trommel Screen 8m Feeding Conveyor</li> <li>• Trommel Screen 8m.</li> <li>• Organic Collect Conveyor</li> <li>• Organic Conveyor</li> <li>• Sorting Plant</li> <li>• Reject Conveyor</li> <li>• Reject Distribution Conveyor</li> <li>• Primary Shredder Feed Conveyor</li> <li>• Primary Shredder</li> <li>• Primary Shredder Output Conveyor</li> <li>• Fixed Trommel Screen 4 M</li> <li>• Organic Conveyor 2</li> <li>• Windshifter Feeding Conveyor</li> <li>• Windshifter</li> <li>• Heavy Material Conveyor</li> <li>• Secondary Shredder Feed Conveyor</li> <li>• Magentic Conveyor</li> <li>• Magentic Conveyor Holder</li> <li>• Secondary Shredder</li> <li>• Shredded Material Conveyor 1</li> <li>• Shredded Material Conveyor 2</li> </ul>



Picture no. (7): Windshifter

## PROJECT DESCRIPTION SHEET

<b>Project Name</b>	Design Manufacture ,Supply,erection and construction of MSW sorting ,recycling and composting plant
<b>Project location</b>	Mahala El Kobra (Gharbyah Governorate ) - Egypt
<b>Project Capacity</b>	320Ton/day
<b>Required Expertise</b>	Engineering Capabilities in Design
<b>Project Duration</b>	March 2015 –Dec. 2015
<b>Project Description</b>	<p>Gharbyah Governorate, through its technical sector, signed an agreement with the Ministry of Military Production to serve the Governorate capital. ENTAG has signed a contracts with the (Ministry of Military Production ) to serve as an engineering contractor.</p> <p>ENTAG provided the following services: Process design ,site and topographical surveys;geotechnical investigations; detailed design and engineering for all civil, architectural, electrical works and mechanical equipment. Supply of imported equipment. Construction management, supervision; testing , commissioning and start-up services.</p>



## PROJECT DESCRIPTION SHEET

<b>Project Name</b>	Design Manufacture ,Supply,erection and construction of MSW sorting ,recycling and composting plant
<b>Project location</b>	Hosh Issa (Bahira Governorate ) - Egypt
<b>Project Capacity</b>	480Ton/day
<b>Required Expertise</b>	Engineering Capabilities in Design
<b>Project Duration</b>	Jan. 2015 – Sep. 2015
<b>Project Description</b>	<p>Bahira Governorate, through its technical sector, signed an agreement with the Ministry of Military Production to serve the Governorate capital. ENTAG has signed a contracts with the ( Ministry of Military Production ) to serve as an engineering contractor.</p> <p>ENTAG provided the following services: Process design ,site and topographical surveys;geotechnical investigations; detailed design and engineering for all civil, architectural, electrical works and mechanical equipment. Supply of imported equipment. Construction management, supervision; testing , commissioning and start-up services.</p>

## PROJECT DESCRIPTION SHEET

<b>Project Name</b>	<b>Design Manufacture ,Supply,erection and construction of MSW sorting ,recycling and composting plant</b>
<b>Project location</b>	Defra (Gharbyah Governorate ) - Egypt
<b>Project Capacity</b>	320Ton/day
<b>Required Expertise</b>	Engineering Capabilities in Design
<b>Project Duration</b>	Jan. 2015 – Jun.2015
<b>Project Description</b>	<p>Gharbyah Governorate, through its technical sector, signed an agreement with the Ministry of Military Production to serve the Governorate capital. ENTAG has signed a contracts with the (Ministry of Military Production ) to serve as an engineering contractor.</p> <p>ENTAG provided the following services: Process design ,site and topographical surveys;geotechnical investigations; detailed design and engineering for all civil, architectural, electrical works and mechanical equipment. Supply of imported equipment. Construction management, supervision; testing , commissioning and start-up services.</p>

## PROJECT DESCRIPTION SHEET

<b>Project Name</b>	<b>Development of transfer stations for Khartoum state.</b>
<b>Project Location</b>	Khartoum State–Republic of Sudan.
<b>Project Capacity</b>	800 ton/day
<b>Project Location</b>	Om Durman city -Khartoum State & Khartoum Bahari state –Republic of Sudan.
<b>Project Capacity</b>	400 ton/day
<b>Project Duration</b>	Nov.2014.
<b>Required Expertise</b>	<ul style="list-style-type: none"> <li>▪ Engineering Capabilities in designing and development of transfer stations.</li> <li>▪ Designing of mechanical equipment.</li> </ul>
<b>Project Description</b>	<p>ENTAG had signed a contract with <b>Khartoum state- General Administration for the Development</b> to develop the transfer stations for Khartoum state.</p> <ul style="list-style-type: none"> <li>▪ Electromechanical Supply.</li> <li>▪ Electrical works for supplied items.</li> <li>▪ Erection of supplied Electromechanical.</li> <li>▪ Commissioning &amp; start up and training for one week.</li> </ul>

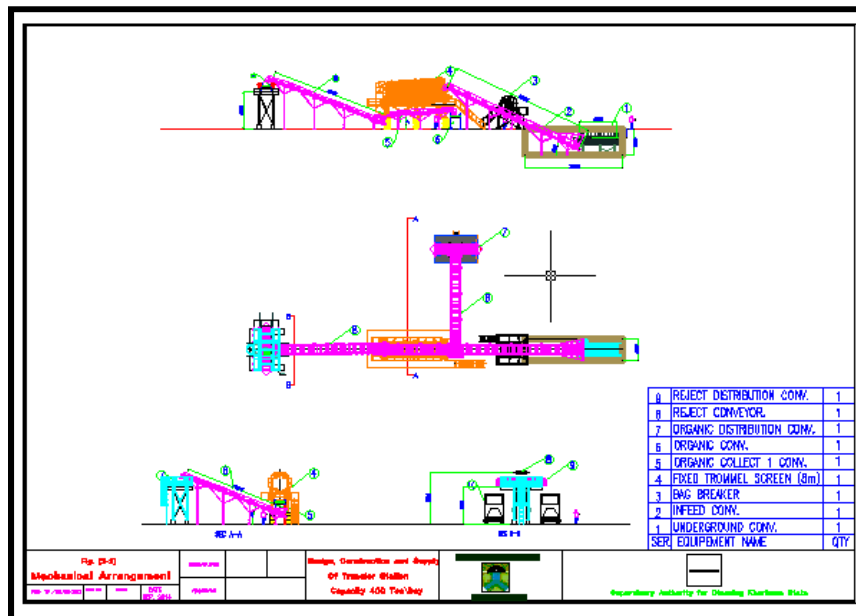

Picture no. (8): Umbada Mechanical arrangement

## PROJECT DESCRIPTION SHEET

<b>Project Name</b>	<b>Manufacturing of Household Refuse Containers.</b>
<b>Project location</b>	Khartoum state – Republic of Sudan.
<b>Project Duration</b>	Nov.2014.
<b>Required Expertise</b>	Design and Manufacturing of Household Refuse Container
<b>Project Description</b>	<p>Design and Manufacturing of 560 Household Refuse Container:</p> <ul style="list-style-type: none"><li>▪ <b>Dimension:</b> 120 length x 120 width x 110 height.</li><li>▪ <b>Steel plates:</b> All made of ASTM A36 3mm thickness or equivalent - Continuous inside welding.</li><li>▪ <b>Paint:</b> First coat of epoxy primer 40 micron. Second coat green epoxy 60 micron. All steel surfaces prepared free of rust and contaminations</li><li>▪ <b>Wheels:</b> (8) Inch (heavy duty) tow with brake &amp; tow without brake</li></ul>



Picture no. (9):Household Refuse Container

## PROJECT DESCRIPTION SHEET

<b>Project Name</b>	<b>Rehabilitation of the Existing MRF</b>
<b>Project location</b>	Khosoos - Khanka - Egypt
<b>Project Capacity</b>	15 ton / hr.
<b>Required Expertise</b>	Engineering Capabilities in Rehabilitation
<b>Project Duration</b>	From October 2014 till Jan. 2015
<b>Project Description</b>	<p>Entag has signed a contract with GIZ ( the Deutsche Gesellschaft fur international zusammenarbeit) Gmbh (german Development cooperation) for Rehabilitation of the existing MRF with total capacity 15 ton / hr.</p> <p>Entag scope of work is Inspection, check, disassembly, supply new parts instead of the defective parts for work completion and the right operation, installation and reassembly of all supplies and accessories for the following equipments:</p> <ul style="list-style-type: none"><li>• In feed conveyor</li><li>• Sorting Conveyor</li><li>• Bag Breaker</li><li>• over belt magnet</li><li>• Organic conveyor</li><li>• Reject conveyor</li><li>• Trommel Screen</li><li>• Electrical works.</li></ul>



Picture no. (10): Feeding conveyor and bag breaker after rehabilitation process

## PROJECT DESCRIPTION SHEET

<b>Project Name</b>	<b>Supply 6 Turning Machines</b>
<b>Project Location</b>	Abu Zaabal Engineering Industries Co.(AZE) (Factory 100) – Egypt.
<b>Project Capacity</b>	Engine Diesel motor 185 HP
<b>Project Duration</b>	October 2014 – June. 2015
<b>Required Expertise</b>	Engineering Capabilities
<b>Project Description</b>	ENTAG had signed a contract with Abu Zaabal Engineering Industries Co for supplying 6 Turning Machines.



Picture no. (11): Turning Machine



## PROJECT DESCRIPTION SHEET

<b>Project Name (phase 5 )</b>	<b>Design Manufacture ,Supply,erection and construction of MSW sorting ,recycling and composting plant</b>
<b>Project location</b>	Zagazig (Sharkya Governorate ) - Egypt
<b>Project Capacity</b>	160Ton/day
<b>Required Expertise</b>	Engineering Capabilities in Design
<b>Project Duration</b>	Sep. 2014 – April 2015
<b>Project Description</b>	<p>The Ministry of local development, through its technical sector, signed an agreement with the extension of one line to the existing facility for construction of MSW sorting ,recycling and composting plant of Zagazig plant, to serve the Governorate capital, ENTAG has signed a contracts with the ( Ministry of Military Production ) to serve as an engineering contractor for phase 5.</p> <p>ENTAG provided the following services: Process design ,site and topographical surveys;geotechnical investigations; detailed design and engineering for all civil, architectural, electrical works and mechanical equipment. Supply of imported equipment. Construction management, supervision; testing, commissioning and start-up services.</p>

## PROJECT DESCRIPTION SHEET

<b>Project Name (phase 5 )</b>	<b>Design Manufacture ,Supply,erection and construction of MSW sorting ,recycling and composting plant</b>
<b>Project location</b>	Senblaween (Dakahlyah Governorate ) - Egypt
<b>Project Capacity</b>	160Ton/day
<b>Required Expertise</b>	Engineering Capabilities in Design
<b>Project Duration</b>	Aug.2014 – Jun.2015
<b>Project Description</b>	<p>The Ministry of local development, through its technical sector, signed an agreement with the construction of MSW sorting ,recycling and composting plant of Senblaween plant, to serve the Governorate capital. ENTAG has signed a contracts with the ( Ministry of Military Production ) to serve as an engineering contractor for phase 5.</p> <p>ENTAG provided the following services: Process design ,site and topographical surveys;geotechnical investigations; detailed design and engineering for all civil, architectural, electrical works and mechanical equipment. Supply of imported equipment. Construction management, supervision; testing , commissioning and start-up services.</p>

## PROJECT DESCRIPTION SHEET

<b>Project Name</b>	<b>Supply 3 Rejects Continuous Balers with its feeding Conveyors</b>
<b>Project Location</b>	Maadi company for Engineering Manufactures- (factory 54) – Egypt.
<b>Project Capacity</b>	14 ton/hr
<b>Project Duration</b>	August 2014 – April. 2015
<b>Required Expertise</b>	Engineering Capabilities
<b>Project Description</b>	ENTAG had signed a contract with Maadi company for Engineering Manufactures for supplying 3 Rejects Continuous Balers with its feeding Conveyors.



Picture no. (12): Rejects Continues Baler

## PROJECT DESCRIPTION SHEET

<b>Project Name</b>	<b>Design Manufacture ,Supply,erection and construction of MSW sorting ,recycling and composting plant</b>
<b>Project location</b>	Abo balah (Ismailia Governorate) - Egypt
<b>Project Capacity</b>	320 Ton/day
<b>Project Duration</b>	Jun. 2014 – Feb 2015
<b>Required Expertise</b>	Engineering Capabilities in Design
<b>Project Description</b>	<p>Ismailia Governorate, through its technical sector, signed an agreement with the Ministry of Military Production to serve the Governorate capital. ENTAG has signed a contracts with the (Ministry of Military Production ) to serve as an engineering contractor.</p> <p>ENTAG provided the following services: Process design,site and topographical surveys;geotechnical investigations; detailed design and engineering for all civil, architectural, electrical works and mechanical equipment. Supply of imported equipment. Construction management, supervision; testing, commissioning and start-up services.</p>

## PROJECT DESCRIPTION SHEET

<b>Project Name</b>	<b>Integrated Resource Recovery Center (IRRC)</b>
<b>Project location</b>	Khosoos - Khanka - Egypt
<b>Project Capacity</b>	15 ton / hr.
<b>Project Duration</b>	From Mar. 2014 till Sep. 2014
<b>Required Expertise</b>	Designing , manufacturing and supplying of a complete set of technological equipment for the sorting of recyclable waste materials and production of refuse derived fuel (RDF) for the cement industry.
<b>Project Description</b>	<p>Entag has signed a contract with GIZ (the Deutsche Gesellschaft fur international zusammenarbeit) GmbH (german Development cooperation) for the Integrated Resource Recovery Center (IRRC) with total capacity 15 ton / hr.</p> <p>Entag is providing the following services: assembly and erection of the technological equipment; all necessary electrical, civil and ancillary works; testing, commissioning and handing over of technological equipment.</p>



Picture no. (13): GIZ project

## PROJECT DESCRIPTION SHEET

<b>Project Name</b>	<b>Design and Construction of an Engineered landfill in Thumrayt</b>
<b>Project location</b>	Sultanate of Oman
<b>Project Capacity</b>	Cell capacity 2,000,000 m <sup>3</sup> .
<b>Project Duration</b>	From 5 Jan. 2014 till 5 Jan. 2015
<b>Required Expertise</b>	Design and Construction of sanitary landfill facility.
<b>Project Description</b>	<p>ENTAG have made a joint venture agreement with Al Salsabeel Trading &amp; Cont. Est (STCE) – Omani Company.</p> <p>ENTAG/STCE JV has signed a contract with Oman Environmental services holding company (Bea'h) for design and construction of an Engineered landfill in Thumrayt with cell capacity 2,000,000 m<sup>3</sup></p> <p>Entag is providing the following services:</p> <ul style="list-style-type: none"><li>• Excavation, grading and compaction of the landfill cell.</li><li>• Embankment and anchoring trench.</li><li>• Construction of the leachate and gas collection systems and evaporation pond.</li><li>• Construction of groundwater monitoring wells.</li><li>• Procurement of materials for the construction of the landfill cell, leachate and gas collection systems and evaporation ponds.</li><li>• Mobilization and demobilization of the specialized manpower and equipment for the construction of the landfill cell, leachate and gas collection systems and evaporation pond.</li></ul>



Picture no. (14): Cell Construction



## PROJECT DESCRIPTION SHEET

<b>Project Name</b>	<b>Design and construction of municipal solid waste sorting, Recycling and Composting plant.</b>
<b>Project Location</b>	Ras Shoqir-Red Sea governorate– Egypt.
<b>Project Capacity</b>	20ton / day.
<b>Project Duration</b>	September 2012 – December 2012
<b>Required Expertise</b>	Engineering Capabilities
<b>Project Description</b>	<p>ENTAG had signed a contract with UNITED ENVIRONMENTAL, INC. for Design and construction of municipal solid waste sorting, Recycling and Composting plant.</p> <p>ENTAG is providing the following services: Process design, site and topographical surveys; geotechnical investigations; detailed design and engineering for all civil, electrical works and mechanical equipment. Supply of equipment. Construction, Erection; Commissioning and Start– up services.</p>



Picture no. (15):Sorting unit–RasShoqir – Egypt.

## PROJECT DESCRIPTION SHEET

<b>Project Name (phase 5 )</b>	<b>Design Manufacture ,Supply,erection and construction of MSW sorting ,recycling and composting plant</b>
<b>Project location</b>	Koum Hamadah (Bahira Governorate ) - Egypt
<b>Project Capacity</b>	160Ton/day
<b>Project Duration</b>	April 2012 – Oct. 2013
<b>Required Expertise</b>	Engineering Capabilities in Design
<b>Project Description</b>	<p>The Ministry of local development, through its technical sector, signed an agreement with the construction of MSW sorting ,recycling and composting plant ofKoum Hamadah plant, to serve the Governorate capital. ENTAG has signed a contracts with the ( Ministry of Military Production ) to serve as an engineering contractor for phase 5.</p> <p>ENTAG provided the following services: Process design ,site and topographical surveys;geotechnical investigations; detailed design and engineering for all civil, architectural, electrical works and mechanical equipment. Supply of imported equipment. Construction management, supervision; testing, commissioning and start-up services.</p>

## PROJECT DESCRIPTION SHEET

<b>Project Name</b>	<b>Engineering, procurement and construction management of landfill.</b>
<b>Project Location</b>	Lagos State Government- Nigeria
<b>Project Capacity</b>	360 ton / day.
<b>Project Duration</b>	2012
<b>Required Expertise</b>	Engineering Capabilities
<b>Project Description</b>	<p>ENTAG had signed a contract combination with Konsadem Associates LTD Company for Lagos state government for the engineering, procurement and construction management of landfill including all associated buildings, weighbridges, roads, landscape, site security, and utilities.</p> <p>The scope of work includes site selection, site investigations, survey, development of master plan, preparation of preliminary and final drawings and design documentations, as well as construction management and 6-month training on operation.</p> <p>ENTAG is providing the following services:</p> <ul style="list-style-type: none"><li>• Site selection</li><li>• Site investigations,</li><li>• Survey,</li><li>• Development of master plan,</li><li>• Preparation of preliminary and final drawings</li><li>• Design documentations,</li><li>• As well as construction management and 6-month training on operation.</li></ul>

## PROJECT DESCRIPTION SHEET

<b>Project Name</b>	<b>Design and build municipal solid waste recycling and treatment plant</b>
<b>Project Location</b>	Lagos State Government- Nigeria
<b>Project Capacity</b>	900ton / day.
<b>Project Duration</b>	November 2011
<b>Required Expertise</b>	Engineering Capabilities
<b>Project Description</b>	<p>ENTAG had signed a contract combination withKonsadem Associates LTD Company forLagos state government for supplying &amp; constructing a complete sorting unit as a turnkey project (design phase). ENTAG is providing the following services:</p> <ul style="list-style-type: none"> <li>• Site survey.</li> <li>• Soil investigation.</li> <li>• Assess utility site requirements.</li> <li>• Develop design criteria.</li> <li>• Develop site master plan.</li> <li>• Prepare preliminary design report.</li> <li>• Prepare calculation sheets for all project components.</li> <li>• Preparing drawings and technical specifications for buildings road and infrastructure, MRF, composting facility and balefill (Epe Site).</li> <li>• Prepare bill of engineering measurements and initial cost estimates.</li> <li>• Prepare implementation time schedule.</li> </ul>



Picture no. (16): Integrated waste management project- Nigeria

## PROJECT DESCRIPTION SHEET

<b>Project Name (phase 5 )</b>	<b>Design Manufacture ,Supply,erection and construction of MSW sorting ,recycling and composting plant.</b>
<b>Project location</b>	Kossyah (Asuit Governorate ) – Egypt.
<b>Project Capacity</b>	160Ton/day.
<b>Required Expertise</b>	Engineering Capabilities in design.
<b>Project Duration</b>	Oct. 2011 – Oct.2014
<b>Project Description</b>	<p>The Ministry of local development, through its technical sector, signed an agreement with the construction of MSW sorting ,recycling and composting plant ofKossyah plant, to serve the Governorate capital. ENTAG has signed a contracts with the (Ministry of Military Production ) to serve as an engineering contractor for phase 5.</p> <p>ENTAG provided the following services: Process design ,site and topographical surveys;geotechnical investigations; detailed design and engineering for all civil, architectural, electrical works and mechanical equipment. Supply of imported equipment. Construction management, supervision; testing, commissioning and start-up services.</p>

## PROJECT DESCRIPTION SHEET

<b>Project Name</b>	<b>Supplying, installing equipments for composting plant for Sultan Qaboos farm in Oman</b>
<b>Project location</b>	Muscat - Oman
<b>Project capacity</b>	2 Trommel screens and 2 Hammer mills
<b>Project Duration</b>	May 2011 – October 2011
<b>Required Expertise</b>	Engineering Capabilities
<b>Project Description</b>	ENTAG signed a contract with Oman technical agency for supplying two mobile trommel screens which separate fines particles from over size one, The trommel screen production capacity is 2-3 ton/hr, and supplying two hammer mill which milling different types of dry agricultural waste such as maize stalks, the hammer mill production capacity is 1.5 ton/hr.

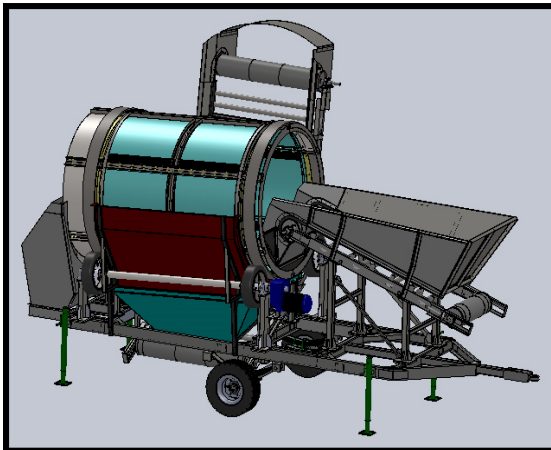

Picture no. (17): Composting equipment for Sultan Qaboos farm  
- Oman



## PROJECT DESCRIPTION SHEET

<b>Project Name</b>	<b>Design, supplying and installing equipments for municipal solid waste transfer station</b>
<b>Project location</b>	Muscat Municipality - Oman
<b>Project capacity</b>	800 ton /day
<b>Project Duration</b>	February 2011 - June 2011
<b>Required Expertise</b>	Engineering Capabilities
<b>Project Description</b>	ENTAG signed a contract with Muscat Municipality for supplying & erection equipment for transfer station . ENTAG is providing the following services: Process design ;detailed design and engineering for mechanical equipment. Supply of equipment,erection and commissioning.



Picture no. (18): Muscat transfer station - Oman

## PROJECT DESCRIPTION SHEET

<b>Project Name</b>	<b>The design, procurement, construction, operation and training of Tartos landfill facility</b>
<b>Project Location</b>	Tartous - Syria
<b>Project Capacity</b>	126 ton / day
<b>Project Duration</b>	2011 - 2015
<b>Required Expertise</b>	Engineering Capabilities
<b>Project Description</b>	<p>ENTAG had signed a contract with Military Construction company for the design, procurement, construction, operation and training of Tartos landfill facility</p> <p>The scope of work included the EPC for landfill cell accordance to USEPA standards, leachate management system, two weighbridges, administration building, laboratory, roads, surface runoff, landscape and fencing. The project was completed to the full satisfaction of the client: Military Construction Company.</p>



Picture no. (19): Tartous balefill facility- Syria

## PROJECT DESCRIPTION SHEET

<b>Project Name</b>	<b>Design, supplying, installing operation mechanical and electrical equipment for municipal solid waste treatment plant.</b>
<b>Project Location</b>	Tartous - Syria
<b>Project Capacity</b>	315ton / day
<b>Project Duration</b>	2011 –2015
<b>Required Expertise</b>	Engineering Capabilities
<b>Project Description</b>	<p>ENTAG had signed a contract with Military Construction company for supplying &amp; constructing a complete sorting unit as a turnkey project.</p> <p>ENTAG is providing the following services: Process design, site and topographical surveys; geotechnical investigations; detailed design and engineering for all civil, electrical works and mechanical equipment. Supply of equipment. Construction, Erection; Commissioning and Start– up services.</p>



Picture no. (20): Tartous municipal solid waste sorting and recycling plant - Syria

## PROJECT DESCRIPTION SHEET

<b>Project Name</b>	<b>Design Manufacture ,Supply,erection and construction of MSW sorting ,recycling and composting plant.</b>
<b>Project location</b>	Farscor (Damietta Governorate ) - Egypt.
<b>Project Capacity</b>	480Ton/day.
<b>Project Duration</b>	Dec. 2010 – May 2014
<b>Required Expertise</b>	Engineering Capabilities in Design.
<b>Project Description</b>	<p>Damietta Governorate, through its technical sector, signed an agreement with the Ministry of Military Production to serve the Governorate capital.ENTAG has signed a contracts with the (Ministry of Military Production ) to serve as an engineering contractor.</p> <p>ENTAG provided the following services: Process design ,site and topographical surveys;geotechnical investigations; detailed design and engineering for all civil, architectural, electrical works and mechanical equipment. Supply of imported equipment. Construction management, supervision; testing, commissioning and start-up services.</p>

## PROJECT DESCRIPTION SHEET

<b>Project Name</b>	<b>Design, supplying and construction of municipal solid waste sorting and recycling plant</b>
<b>Project Location</b>	Jeddah – Kingdom of Saudi Arabia.
<b>Project Capacity</b>	4200ton / day.
<b>Project Duration</b>	October 2009 – April 2010
<b>Required Expertise</b>	Engineering Capabilities
<b>Project Description</b>	<p>ENTAG had signed a contract with Seder Group Trading &amp; Contracting Company for supplying &amp; constructing a complete sorting unit as a turnkey project.</p> <p>ENTAG is providing the following services: Process design, site and topographical surveys; geotechnical investigations; detailed design and engineering for all civil, electrical works and mechanical equipment. Supply of equipment. Construction, Erection; Commissioning and Start– up services.</p>



Picture no. (21): Seder municipal solid waste sorting and recycling plant  
– Jeddah KSA

## PROJECT DESCRIPTION SHEET

<b>Project Name</b>	<b>Design and build municipal solid waste sorting and recycling plant</b>
<b>Project Location</b>	Om Durman - Republic of Sudan
<b>Project Capacity</b>	960ton / day.
<b>Project Duration</b>	Aug. 2009 – Dec 2009
<b>Required Expertise</b>	Engineering Capabilities
<b>Project Description</b>	<p>ENTAG had signed a contract with Omdurman company for supplying &amp; constructing a complete sorting unit as a turnkey project.</p> <p>ENTAG is providing the following services: Process design, site and topographical surveys; geotechnical investigations; detailed design and engineering for all civil, electrical works and mechanical equipment. Supply of equipment. Construction, Erection; Commissioning and Start– up services.</p>



Picture no. (22): Om Dorman municipal solid waste sorting and recycling plant - Sudan



## PROJECT DESCRIPTION SHEET

<b>Project Name</b>	<b>Provide the mechanical supply, machinery and laboratory equipment necessary to the construction and operation of palm waste recycling plant in The New Valley</b>
<b>Project Location</b>	El Kharga - New Valley
<b>Project Capacity</b>	50ton / day.
<b>Project Duration</b>	May 2009 – July 2009
<b>Required Expertise</b>	Engineering Capabilities
<b>Project Description</b>	<p>ENTAG had signed a contract with agriculture Directorate in New Valley for Provide the mechanical supply, machinery and laboratory equipment necessary to the construction and operation of palm waste recycling plant in The New Valley.</p> <p>ENTAG is providing the following services: Process design detailed design and engineering for mechanical equipment. Supply of equipment, erection and commissioning,</p>

## PROJECT DESCRIPTION SHEET

<b>Project Name</b>	<b>Supplying equipments for non-conventional feed production from agriculture residue.</b>
<b>Project Location</b>	Kalabsho (Dakahlia) – MitGaber (sharkeya) – Elzahaween (Kalubia) – Mahalazeyad ( gharbeya)
<b>Project Capacity</b>	50 ton / day.
<b>Project Duration</b>	April 2009 until present
<b>Required Expertise</b>	Engineering Capabilities
<b>Project Description</b>	<p>The project will take advantage of the biomass, especially rice straw and turn them into new sources as fodder by raising the nutritional value of these biomass and the addition of some additives and treatment with natural enzymes that work in anaerobic conditions.</p> <p>ENTAG is providing the following services:</p> <ul style="list-style-type: none"><li>- design some of the units required to convert biomass to non-traditional feed.</li><li>- Working inventory of equipment required to run the production line and import.</li><li>- Assembly production– lines and installed.</li><li>- Development necessary for the production units.</li></ul>



Picture no. (23): Supplying equipments for non-conventional feed production from agriculture residue.

## PROJECT DESCRIPTION SHEET

<b>Project Name</b>	<b>Supply turning machine and mobile trommel screen for MSW.</b>
<b>Project capacity</b>	30 ton / hr
<b>Project Location</b>	Veolia Company – Alexandria – Egypt.
<b>Project Duration</b>	Jully 2008 – Nov. 2008
<b>Required Expertise</b>	Engineering Capabilities
<b>Project Description</b>	ENTAG had signed a contract with Veolia Alexandria for supplying mobile trommel screen for MSW to separe organic matter and reject from MSW ENTAG is providing the following services: Supply of trommel screen, Erection, Commissioning and Start – up services.



Picture no. (24): Supply mobile Trommel screen for MSW.

## PROJECT DESCRIPTION SHEET

<b>Project Name</b>	<b>Design, supplying and construction of commercial and industrial waste sorting and recycling plant.</b>
<b>Project Location</b>	Jeddah - Kingdom of Saudi Arabia.
<b>Project Capacity</b>	480 ton / day.
<b>Project Duration</b>	April 2008 – October 2008
<b>Required Expertise</b>	Engineering Capabilities
<b>Project Description</b>	<p>ENTAG had signed a contract with waste collection and recycling co.Ltd (MEPCO) for supplying &amp; constructing a complete sorting unit as a turnkey project.</p> <p>ENTAG is providing the following services: Process design, site and topographical surveys; geotechnical investigations; detailed design and engineering for all civil, electrical works and mechanical equipment. Supply of equipment. Construction, Erection; Commissioning and Start– up services.</p>



Picture no. (25): Commercial, market and industrial waste sorting and recycling plant - KSA

## PROJECT DESCRIPTION SHEET

<b>Project Name</b>	<b>Design and construction of MSW recycling and composting plants.</b>
<b>Project Location</b>	Bani sewaf
<b>Project Capacity</b>	160 ton / day
<b>Project Duration</b>	Dec.2007- Jun 2008
<b>Required Expertise</b>	Engineering services for design, planning, review/approvals Composting Plant siting Design civil electromechanical and process engineering Construction Supervision Commissioning and start-up of composting plants
<b>Project Description</b>	ENTAG signed a contract with Abo Keir Company for manufacture engineering for : <ul style="list-style-type: none"><li>- Establishment of landfill for solid waste</li><li>- Design and operation of landfill</li><li>- Rehabilitation of the industry</li></ul> ENTAG provided the following services: Process design ,site and topographical surveys; geotechnical investigations; detailed design and engineering for all civil, architectural, electrical works and mechanical equipment. Supply of imported equipment. Construction management, supervision; testing, commissioning and start-up services.



Picture no. (26):Design and construction of MSW recycling and composting plants.

## PROJECT DESCRIPTION SHEET

<b>Project Name</b>	<b>Design,Supplying equipments for construction transfer station</b>
<b>Project capacity</b>	140 ton / day
<b>Project location</b>	Qater – El Doha
<b>Project Duration</b>	Oct. 2007- November 2007
<b>Required Expertise</b>	Engineering Capabilities
<b>Project Description</b>	<p>ENTAG signed a contract with Saudi company for Enviromental works for supplying &amp; erection equipment for transfer station at Ras Lafaan industrial city to serve the camp pearl GTL shell .</p> <p>ENTAG is providing the following services: Process design ;detailed design and engineering for mechanical equipment. Supply of equipment,erection and commissioning, The project is under construction.</p> <p>The project main items are:</p> <ul style="list-style-type: none"><li>- size reduction, baling, crushing, weighting.</li></ul>



Picture no. (27): El Doha transfer station - Qatar



## PROJECT DESCRIPTION SHEET

<b>Project Name (phase 5 )</b>	<b>Design Manufacture ,Supply,erection and construction of MSW sorting ,recycling and composting plant</b>
<b>Project location</b>	Manzalah (Dakahlyah Governorate ) - Egypt
<b>Project Capacity</b>	160Ton/day
<b>Project Duration</b>	Jul. 2007 - Dec. 2012
<b>Required Expertise</b>	Engineering Capabilities in Design
<b>Project Description</b>	<p>The Ministry of local development, through its technical sector, signed an agreement with the construction of MSW sorting ,recycling and composting plant of Manzalah plant, to serve the Governorate capital. ENTAG has signed a contracts with the (Ministry of Military Production ) to serve as an engineering contractor for phase 5.</p> <p>ENTAG provided the following services: Process design ,site and topographical surveys;geotechnical investigations; detailed design and engineering for all civil, architectural, electrical works and mechanical equipment. Supply of imported equipment. Construction management, supervision; testing, commissioning and start-up services.</p>

## PROJECT DESCRIPTION SHEET

<b>Project Name</b>	<b>Design Manufacture ,Supply,erection and construction of MSW sorting ,recycling and composting plant</b>
<b>Project location</b>	El Wasta (Bani sueif Governorate ) - Egypt
<b>Project Capacity</b>	160 Ton/day
<b>Project Duration</b>	Jul. 2007 – Jun. 2013
<b>Required Expertise</b>	Engineering Capabilities in Design
<b>Project Description</b>	<p>Bani sueif Governorate, through its technical sector, signed an agreement with the Ministry of Military Production to serve the Governorate capital. ENTAG has signed a contracts with the (Ministry of Military Production ) to serve as an engineering contractor.</p> <p>ENTAG provided the following services: Process design ,site and topographical surveys;geotechnical investigations; detailed design and engineering for all civil, architectural, electrical works and mechanical equipment. Supply of imported equipment. Construction management, supervision; testing, commissioning and start-up services.</p>

## PROJECT DESCRIPTION SHEET

<b>Project Name</b>	<b>Design and construction of recycling and composting plants.</b>
<b>Project Location ( phase 5 )</b>	El Khanka (Kalubia), Sidy Salem ( Kafr el sheih), El senbelawen (Dakahlia), El manzala (Dakahlia), Asuit(Kosyiah), Kom hamada (El behira), Ashmoun ( Monofeya), shohadaa ( Monofeya)
<b>Project Capacity</b>	160 ton / day.
<b>Project Location ( phase 5 )</b>	El Sadat, El zakazig
<b>Project Capacity</b>	320 ton / day.
<b>Project Duration</b>	2007
<b>Required Expertise</b>	Engineering Capabilities in Design
<b>Project Description</b>	<p>The Ministry of local development, through its technical sector, signed an agreement with the construction of 19 composting plants, to serve the Governorate capital, cities as well as marakez level cities. ENTAG has signed a contracts with the ( Ministry of Military Production) to serve as an engineering contractor for Phases 2,3,4 .</p> <p>ENTAG provided the following services: Process design ,site and topographical surveys; geotechnical investigations; detailed design and engineering for all civil, architectural, electrical works and mechanical equipment. Supply of imported equipment. Construction management, supervision; testing, commissioning and start-up services.</p>



Picture no. (28): Design and construction of recycling and composting plants

## PROJECT DESCRIPTION SHEET

<b>Project Name</b>	<b>Provide equipment for collecting, transportation and treatment of agriculture residue.</b>
<b>Project Location</b>	Sharkia, Dakahliya, Gharbia and Qalubia Governorate
<b>Project Capacity</b>	526,000 ton/year
<b>Project Duration</b>	2007 – 2017
<b>Required Expertise</b>	Technology and equipment provider for biomass management process.
<b>Project Description</b>	Egyptian Enviromental Affair Agency (EEAA) signed a contract with ENTAG for providing equipments for biomass management (collection, transportation and treatment) for producing compost, animal feed, pellets, briquettes and altermative fuel to cement plants.



Picture no. (29): Provide equipment for collecting, transportation and treatment of agriculture residue.

## PROJECT DESCRIPTION SHEET

<b>Project Name</b>	<b>Technical support for operation, maintenance and quality control of compost resulted from municipal solid waste in Baidaa City - Libya</b>
<b>Project capacity</b>	160 ton / day
<b>Project location</b>	Baidaa City - Libya
<b>Project Duration</b>	Oct. 2006- January 2007
<b>Required Expertise</b>	Engineering Capabilities
<b>Project Description</b>	ENTAG signed a contract with General Company for business and services in Green Mountain for Technical support for operation, maintenance and quality control of compost resulted from municipal solid waste project in Baidaa City.

## PROJECT DESCRIPTION SHEET

<b>Project Name</b>	<b>Design and construction units for producing compost from agriculture residue (rice straw)</b>
<b>Project Location</b>	Kalabsho 1, 2 ( Dakahliya )
<b>Project Capacity</b>	400 ton/day
<b>Project Duration</b>	Oct. 2005 – march 2006 ( 5 monthes )
<b>Required Expertise</b>	<p>Engineering and Technical Services for the assessment of the plants.</p> <p>Design of composting plants for biomass.</p> <p>Construction supervision.</p> <p>Commissioning and start-up.</p>
<b>Project Description</b>	<p>There are 3 million ton of rice straw produced annually in Egypt, up till now there no efficient method to utilize this quantity, the governorates decided to construct 2 plants for composting part of these residues.</p> <p>The governorates contracted with NOMP for supply and construct these plants.</p> <p>NOMP contracted with entag to provided the following services: Process design ,site and topographical surveys; geotechnical investigations detailed design and engineering for all civil, architectural, electrical works and mechanical equipment. Supply of imported equipment. ( Compost turning machine – hammer mill) Construction management, supervision; testing, commissioning and start-up services.</p>



Picture no. (30): Design and construction units for producing compost from agriculture residue (rice straw)



## PROJECT DESCRIPTION SHEET

<b>Project Name</b>	<b>Design and construction of MSW Sorting &amp;composting plant ( Turnkey project ).</b>
<b>Project capacity</b>	500 ton / day
<b>Project location</b>	Kota Kinabalu – Saba – Malaysia
<b>Project Duration</b>	March 2005 – march 2006 ( 12 monthes )
<b>Required Expertise</b>	Engineering Capabilities
<b>Project Description</b>	<p>ENTAG had signed a contract with Ms Smart Recycling (Malaysia ) for supplying &amp; erection complete sorting &amp; composting plant Saba Area as a turnkey project .</p> <p>ENTAG is providing the following services: Process design , site and topographical surveys;detailed design and engineering for all civil, architectural , electrical works and mechanical equipment. Supply of equipment. Construction,erection; commissioning, The project is under construction.</p> <p>The project main items are:</p> <ol style="list-style-type: none"><li>1- One reception and sorting building including three sorting lines.</li><li>2- Composting area with compost turning machines and water addition trucks.</li><li>3- Design of steel &amp; building of compost refining area.</li><li>4- Decomentation engineering, training and spare parts.</li></ol>



Picture no. (31):Design and construction of MSW Sorting &composting plant - Malaysia

## PROJECT DESCRIPTION SHEET

<b>Project Name</b>	<b>Upgrading El- Montaza sorting unit</b>
<b>Project capacity</b>	240 ton / day
<b>Project Location</b>	Montaza – Alexandria – Egypt
<b>Project Duration</b>	March 2004 – Sept. 2004
<b>Required Expertise</b>	Engineering Capabilities in Upgrading
<b>Project Description</b>	<p>ENTAG had signed a contract with Onyx Alexandria for supplying &amp; constructing a complete sorting unit as a turnkey project. To serve as upgrading unit for the existing MSW sorting and composting plant.</p> <p>ENTAG is providing the following services: Process design , site and topographical surveys ; geotechnical investigations ;detailed design and engineering for all civil, electrical works and mechanical equipment. Supply of equipment. Construction, Erection ; Commissioning and Start – up services.</p> <p>The project complete at August 2004 by then the plant will be able to receive 400 ton/day of MSW instead of current capacity which is 160 ton/day.</p>



Picture no. (32): Upgrading El- Montaza sorting unit project

## PROJECT DESCRIPTION SHEET

<b>Project Name</b>	<b>Landfilling and processing services for Southern Zone in Cairo</b>
<b>Project Location</b>	15 th May ,city Cairo, Egypt
<b>Project Capacity</b>	1500 ton /day
<b>Project Duration</b>	2004 – 2005
<b>Required Expertise</b>	Design and supervision
<b>Project Description</b>	<p>Entag awarded a contract with Ecaru for Cairo South processing &amp; landfilling services for design and supervision of the project.</p> <p>Engineering, design and supply of landfill</p> <ul style="list-style-type: none"><li>- including topographical surveys</li><li>- geotechnical investigations, detailed design and engineering for all civil, architectural, electrical works and mechanical equipment</li><li>- supervision</li></ul>



Picture no. (33): Land filling and processing services for Southern Zone - Cairo

## PROJECT DESCRIPTION SHEET

<b>Project Name</b>	<b>Design and construction recycling and composting plants.</b>
<b>Project Location ( phase 4 )</b>	Abu-Keber (Sharkeia),Damietta, El-Kharga( New Valley) , Nga Hamady (Qena), Edco (Benira), Zakzik (Sharkia).
<b>Project Capacity</b>	160 ton/day
<b>Project Location ( phase 4 )</b>	Aga( Dakahilia), Gharbia Tanta.
<b>Project Capacity</b>	320 ton/day
<b>Project Duration</b>	Apri 2003– April 2004
<b>Required Expertise</b>	Engineering services for design, planning, review/approvals Composting Plant siting Design civil electromechanical and process engineering Construction Supervision Commissioning and start-up of composting plants
<b>Project Description</b>	The Ministry of local development, through its technical sector, signed an agreement with the construction of 32 composting plants, to serve the Governorate capital, cities as well as marakez level cities. ENTAG has signed a contracts with the ( Ministry of Military Production) to serve as an engineering contractor for Phases 2,3,4 .  ENTAG provided the following services: Process design ,site and topographical surveys; geotechnical investigations; detailed design and engineering for all civil, architectural, electrical works and mechanical equipment.Supply of imported equipment. Construction management, supervision; testing, commissioning and start-up services.



Picture no. (34):Design and construction recycling and composting plants.

## PROJECT DESCRIPTION SHEET

<b>Project Name</b>	<b>Design, supplying and construction of two sorting units for upgrading EL SAWANY MSW treatment plant.</b>
<b>Project location</b>	El Sawany – Tripoli
<b>Project Capacity</b>	500 ton/day, (One shift, 8 hr)
<b>Project Duration</b>	Nov 2001-Nov 2002
<b>Required Expertise</b>	Engineering Capabilities
<b>Project Description</b>	<p>Environmental Protection Agency has a large factory in Tripoli ( Sawani area ) for domestic solid waste recycling with capacity of 500 tons/day and turned off from work</p> <p>Environmental Protection Agency required from the company to add units for upgrade and re-operate the plant at full capacity, commensurate with the nature of the waste contained</p> <p>Implementation and operation the upgrading units</p> <p>All business have been implemented within a set of contracts include the operation and management of the plant.</p> <p>The factory production of organic compost has contributed in the development of agricultural projects in Libya particularly the cultivation of palm trees on a large scale project in addition to various types of cultivations.</p>



Picture no. (35): EL SAWANY MSW treatment plant - Libya



## PROJECT DESCRIPTION SHEET

<b>Project Name</b>	<b>Design, supplying and construction unit for converting MSW to compost- Sedy El Sayeh</b>
<b>Project capacity</b>	320 ton / day
<b>Project location</b>	Sedy El Sayh – Tripoli – Libya
<b>Project Capacity</b>	320 ton /day in addition to 5 plants with capacity 160 ton/day
<b>Project Duration</b>	Nov 2001-2002
<b>Required Expertise</b>	Engineering Capabilities in Design
<b>Project Description</b>	<p>ENTAG had signed a contract with Environmental Protection Agency (Tripoli Municipality) for supplying &amp; constructing and operating Sedi – El Sayeh plant as a turnkey project to convert waste to organic compost with capacity 320 ton / day, which works efficiently in full since 2002 and until now.</p> <p>In addition to the 4 other factories with capacity 160 ton / day per plant.</p>



Picture no. (36):Sedy El Sayeh MSW sorting & composting Turnkey plant - Libya



## PROJECT DESCRIPTION SHEET

<b>Project Name</b>	<b>Design and construction recycling and composting plant for El ObourMarket</b>
<b>Project Location</b>	El Obour Market for vegetables and fruits, Cairo
<b>Project Capacity</b>	200 ton/day
<b>Project Duration</b>	January 2000 – September 2000
<b>Required Expertise</b>	<p>Engineering and Technical Services for the assessment of the plants.</p> <p>Design of composting plants for biomass .</p> <p>Construction supervision.</p> <p>Commissioning and start-up.</p>
<b>Project Description</b>	<p>El Obour market is the biggest vegetables, fruit, and fish wholesale market in Egypt. More than 150 ton wastes per day are produced. The executionist for the market financed a composting plant for turning the market waste into compost .</p> <p>ENTAG provided the following services: Process design ,site and topographical surveys; geotechnical investigations detailed design and engineering for all civil, architectural, electrical works and mechanical equipment. Supply of imported equipment. ( Compost turning machine – star screen – skid loaders – hammer mill – bagging machine) Construction management, supervision; testing, commissioning and start-up services.</p>
<b>Note</b>	Plant is in operation, rented by ECARU for 4 <sup>th</sup> year producing high quality composting.



Picture no. (37): Design and construction recycling and composting plant for El Obour Market- Egypt.

## PROJECT DESCRIPTION SHEET

<b>Project Name</b>	<b>Design and construction of MSW recycling and composting plants.</b>
<b>Project Location ( phase 3 )</b>	Beala( Kafr EL Sheikh), Semesta( Bani Suif), Qena ,Edfu, Kafr Eldawar( Behaira), Meet Ghamer (Dakahliya) ,Mallawi( Minia), Ras El Bar (Damietta), And Belbis (Sharkeia) - Egypt
<b>Project Capacity</b>	160 ton/day
<b>Project Duration</b>	July 1999 – 2001,
<b>Project Location</b>	15th May City, Cairo
<b>Capacity</b>	960 ton/day, 640 ton/day
<b>Required Expertise</b>	Engineering Capabilities in Design
<b>Project Description</b>	<p>The Ministry of local development, through its technical sector, signed an agreement with the Ministry of Military Production for the construction of 32 composting plants, to serve the Governorate capital, cities as well as marakez level cities. ENTAG has signed a contracts the Ministry of Military Production to serve as an engineering contractor for Phases 2,3,4 .</p> <p>All plants are completed and currently in operation.</p> <p>ENTAG provided the following services: Process design ,site and topographical surveys; geotechnical investigations; detailed design and engineering for all civil, architectural, electrical works and mechanical equipment.Supply of imported equipment. (turning machines , loaders and belt magnets)</p> <p>Construction management, supervision; testing, commissioning and start-up services.</p>



Picture no. (38):Design and construction of MSW recycling and composting plants

## PROJECT DESCRIPTION SHEET

<b>Project Name</b>	<b>Design and construction of MSW sorting, Recycling and composting plant</b>
<b>Project Location</b>	15 th May , Cairo, Egypt
<b>Project Capacity</b>	960 ton /day
<b>Project Duration</b>	1999 – 2001
<b>Required Expertise</b>	Engineering Capabilities in Design
<b>Project Description</b>	<p>The Ministry of local development, through its technical sector, signed an agreement with the Ministry of Military Production for the construction of 15 May sorting, recycling and composting plant in south Cairo, to serve the Governorate capital, cities as well as marakez level cities. ENTAG has signed a contracts the Ministry of Military Production to serve as an engineering contractor All the plant is completed and currently in operation.</p> <p>ENTAG provided the following services: Process design ,site and topographical surveys; geotechnical investigations; detailed design and engineering for all civil, architectural, electrical works and mechanical equipment. Supply of imported equipment. (turning machines , loaders and belt magnets)</p> <ul style="list-style-type: none"> <li>- Construction management, supervision; testing, commissioning and start-up services.</li> </ul>



Picture no. (39): MSW sorting, recycling and composting plant

## PROJECT DESCRIPTION SHEET

<b>Project Name</b>	<b>Design and construction of MSW sorting, recycling and composting plants.</b>
<b>Project Location (phase 2)</b>	Katamiya (Cairo), Kafr El Sheikh, ( Mehalla Gharbiya), Suez, Marsa Matrouh, Arish( North Sinai), Aswan, Sharm El Sheikh (South Sinai), Belquas(Dakahliya), Menouf (Menoufiya), Abu Rawash( Giza), Shabramant (Giza).
<b>Project Capacity</b>	160 ton/day
<b>Project Location (phase 2)</b>	Katamiya 2,3 ( Cairo), Shubrament
<b>Project Capacity</b>	320 ton/day
<b>Project Duration (phase 2)</b>	July 1998 – 1999
<b>Project Description</b>	<p>The Ministry of local development, through its technical sector, signed an agreement with the Ministry of Military Production for the construction of 32 composting plants, to serve the Governorate capital, cities as well as marakez level cities. ENTAG has signed a contracts with the Ministry of Military Production to serve as an engineering contractor for Phases 2,3,4 .</p> <p>All plants are completed and currently in operation.</p> <p>ENTAG provided the following services: Process design ,site and topographical surveys; geotechnical investigations; detailed design and engineering for all civil, architectural, electrical works and mechanical equipment. Supply of imported equipment. Construction management, supervision; testing, commissioning and start-up services.</p>



Picture no. (40): Design and construction of MSW sorting, recycling and composting plant

## PROJECT DESCRIPTION SHEET

<b>Project Name</b>	<b>Common aerobic composting plant for treatment of waste resulted from sewage treatmentPlants</b>
<b>Project Location</b>	District of Zabaleen, Alexandria
<b>Project Duration</b>	Jul. 1995-1996
<b>Project Capacity</b>	50 ton / day
<b>Required Expertise</b>	Engineering services for design, planning, review /approvals Design civil electromechanical and process engineering Construction Supervision. Commissioning and start-up of composting plants.
<b>Project Description</b>	<p>Most of waste resulting from the villages and districts are agricultural and sewage waste This project benefits from these two types of waste by converting to compost Entag designed different treatment methods, units required to establish the project, the detailed design of all work required for the project. These efforts divided into 4 phases:</p> <ol style="list-style-type: none"> <li>1. Collecting the information about the site and the project and make full analysis of all the needs of the project</li> <li>2. Make the tender documents and agreements</li> <li>3. Implementation phase</li> <li>4. Operating factory</li> </ol> <p>The factory is now operating</p>



Picture no. (41): Common aerobic composting for treatment of waste resulted from sewage treatments